

HEATING OF SEWERAGE SLUDGE TRANSFER LINES DATA & SPECIFICATION SHEET

General Description

Inditherm sewerage sludge transfer line heaters are a revolutionary system for preventing the build-up of fatty deposits on the inside of the pipes, using Inditherm's patented conductive polymer technology (CPT) as the heat source. Because CPT provides very even heating, it is able to ensure that there is no build-up of fatty substances within sludge transfer lines (STLs) wherever heat is applied.

The Inditherm heaters are bespoke and can be fitted around any size of pipe or associated equipment in two forms:

- as heating pads under fixed insulation and metal cladding;
- as removable heating jackets for use over pumps and other equipment where maintenance or access is required.

The Situation

Many STLs suffer from the excessive build-up of fatty deposits on the inside walls of the pipes and associated equipment. This necessitates shutting down the STLs for cleaning on a regular basis, sometimes as often as every 4 weeks. There is a significant amount of work involved in cleaning out STLs, which is generally done by jetting out using hot water or steam.

This work has a number of consequences:

- The line has to be shut down for several days.
- Scaffolding may be required for the jetting crew.
- Cleaning the scaffolding following the jetting operation.
- Fitters are required for line breakdown and refitting (approximately 1 day for a typical STL).
- The work area must be cleaned up following jetting operation.
- In the event that the sludge feeds a digester for a combined heat and power (CHP) plant, the plant may need to be closed down.



Build-up of fatty deposits in an unheated 200mm diameter STL

The Solution

The Inditherm heating system eliminates the build-up of sludge in STLs and the associated equipment, such as valves and pumps, eliminating the need to close down and clean the lines, along with the cost and health & safety implications.

Heating with Inditherm completely eliminates any build-up, even on bends



Inditherm Conductive Polymer Technology

Inditherm technology is based on a unique carbon-based polymer that generates uniform heat across its entire surface when energised by a low voltage power source.

The Inditherm conductive polymer technology (CPT) has fabric-like qualities and flexibility that enable it to be used on pipes and on most industrial components, including items with shapes that are normally difficult to heat. In addition, it is ideal for heating large, flat areas.

The Inditherm polymer will be encapsulated in an appropriate, insulated outer cover, depending upon the application. Heated pads can be made to a suitable length to fit between brackets, flanges, etc.

Heating System Features

The Inditherm heating system can be applied under fixed insulation and cladding or as removable heated jackets. Each system consists of the heating and associated low voltage electrical supply.

- **Heating pads under fixed insulation and cladding.** The heating pads use Inditherm's CPT encased in a rugged envelope. This is then strapped to the line before being covered by conventional insulation and metal cladding, as shown below. This is ideal for standard pipe runs and is suitable for STLs of any size or length.

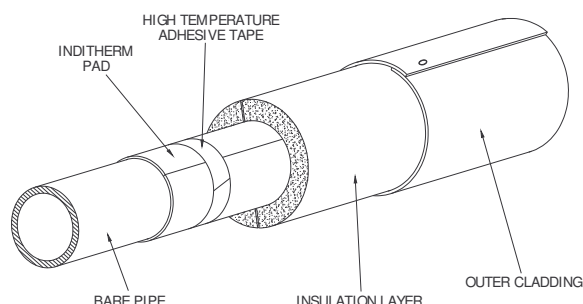

Two STLs, one unheated and the other heated with Inditherm under conventional insulation and metal cladding



- **Removable jacket heaters** are constructed using Inditherm's CPT, mounted on insulation and then encapsulated in soft PVC jackets, fitted with appropriate fasteners. They are usually made to measure.
- **Installation** - fitting removable jackets around pipework and associated equipment is straight-forward and can be completed quickly, minimising time on site. It is normally carried out by Inditherm technicians who will train site operators how to remove and replace the jackets safely.



Removable heated jacket

Specification

Dimensions:	Virtually any size of pipe or associated equipment
Mains Input Voltage:	115 / 230 / 415 Vac 50Hz, as required
Output Voltage:	24Vac to all heating pads
Control Panel:	IP rated mild or stainless steel enclosure; rating depends upon application
Insulation:	As required, from 25mm to 100mm in a variety of materials
Cladding Material:	Stainless steel, aluminium, or Plastisol cladding, as required
Removable Jackets:	Fitted to valves, pumps, and complex surface shapes. Heating pads have insulation enclosed in chemical & water resistant covers, secured by hook & loop fasteners and/or removable straps
Temperature Control:	PID thermostat control to $\pm 2^{\circ}\text{C}$
Temp/Current Protection:	Internal thermal fuse
Temperature Range:	Ambient up to 90°C

About Inditherm plc

Formed in 1998, marketing a new polymer based heating system, Inditherm is established in numerous markets as a cost-effective provider of innovative solutions to difficult heating problems.

Applications include patient warming and muscle heat therapy within the medical sector, critical temperature management within industry, under-pitch heating within sports grounds and as an accelerator for concrete curing in the construction market.

Contact: Inditherm Industrial, Houndhill Park, Bolton Road, Rotherham S63 7LG, United Kingdom
 Tel: +44 (0) 1709 761000; Fax: +44 (0) 1709 761066
 E-mail: sales@indithermplc.com ; Website: www.inditherm.com