

PROCESS HEATING FOR INDUSTRIAL APPLICATIONS

DATA & SPECIFICATION SHEET

General Description

Inditherm specialises in providing heating products and services for critical temperature management and frost protection in process control and storage applications throughout the food processing, confectionary, pharmaceutical, chemical, oil & gas, utility and mining sectors.

Inditherm process heating uses the Company's patented carbon-based polymer technology (CPT) to provide heat to pipework (both single- and twin-walled pipes), pumps, valves, and storage vessels (see separate data sheet). Heating elements can be provided in two alternative forms: pads covered with conventional insulation and cladding or removable, flexible heated jackets. In addition, Inditherm provides unheated removable jackets for frost protection and noise reduction.



Figure 1 - Typical Inditherm Removable Jacket Heaters on a Pump



Figure 2 - Typical Inditherm Heating under Fixed Cladding

Benefits of Inditherm

Traditionally, most process heating has been provided by hot water in dual-walled pipes or by electrical trace heating under fixed insulation and cladding. Both solutions have limitations:

- Maintenance can be difficult, due to restricted access of critical items such as pumps.
- Accurate temperature control is challenging.
- Heat cannot be applied evenly to all whole process surfaces.
- Energy consumption is high.
- There are reliability concerns, either from leaks (hot water) or with durability (trace).
- There are safety concerns.

Using Inditherm for process heating solves these problems:

- With removable jackets, maintenance of key components is simple and the jackets can be replaced quickly and reconnected safely.
- Inditherm offers a variety of temperature control systems, the most accurate of which allows the temperature to be managed to within $\pm 2^{\circ}\text{C}$. Full PLC control is also available.
- Inditherm applies heat over the entire surface area, providing more even heat and eliminating hot spots.
- The energy consumption of Inditherm is typically less than 30% of alternative forms of process heating.
- Inditherm products are designed for durability and experience bears this out. Extended product warranties are available under certain conditions.
- Low voltage (generally 24Vac) is very safe. Removable jackets have no sharp edges on which users can injure themselves. And because Inditherm is so reliable, fixed cladding rarely needs to be removed.

Heating System Features

The Inditherm heating system consists of the following elements:

- **Heaters.** These are constructed using Inditherm's patented CPT. Each pad is individually temperature controlled using a bi-metallic strip or for more accurate control, a PID system can be supplied. There are three main options:
 - **Removable jacket heaters**, in which the CPT is mounted on insulation and then encapsulated in soft PVC jackets, fitted with appropriate fasteners. They are made in a number of standard sizes but are usually made to measure. An example is in Figure 3 below.

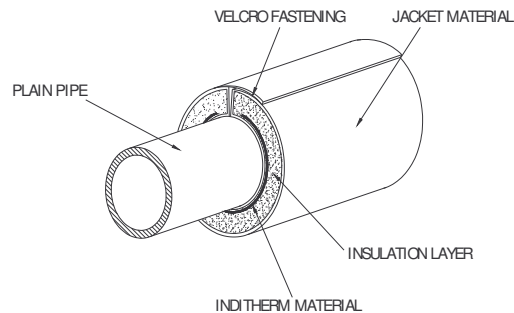

Figure 3 – Removable Jacket

- **Heating pads with fixed cladding.** The CPT is encased in a silicon cloth pad which is taped to the pipework. This is then covered with insulation and clad with an appropriate plastic or metal material (including Plastisol, aluminium, or stainless steel), as shown in Figure 4.

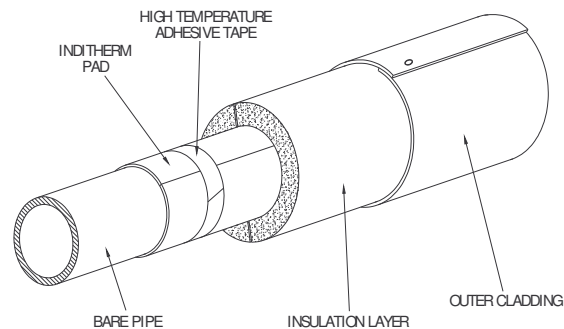

Figure 4 – Heating Pad with Fixed Insulation and Cladding

- **Hybrid systems.** These use a combination of the two systems, with fixed heating on pipework and removable jackets on equipment that requires servicing, as well as flanges or joints that may need to be accessed.
- **Electrical control panels** are standard units or can be manufactured in accordance with the user's own standard specification. They are typically powered from the 415/230/110Vac mains input to a 24Vac output transformer housed in an IP55 rated enclosure with hinged doors and lockable handle assembly. The panels have power-on LED indication and mains isolator switches. All power outlets are protected by individual 25A DIN-rail mounted circuit breakers. Panel wiring is in accordance with BS6231. kWh meters can be fitted, as required. There are several sizes of panel, depending upon the length of the pipework runs. A typical panel can power up to a maximum of 250m of heated pipework.



- Cables and junction boxes.** Cables will vary in rating, depending upon the application. They are sized to provide 16A with the minimal possible voltage drop. Junction boxes are mounted every 10 to 15m, depending upon the rating of the system. In general, each pad is connected in parallel with the next heating pad through an IP65 rated screw plug, as shown below.



**Typical IP65
Junction Box**



**Typical IP65
16A Plug**

Configurations

Inditherm process heating can be applied to both single- and dual-walled pipework. On single-walled pipes, the heating is applied directly to the pipework, as shown in Figure 5 below.

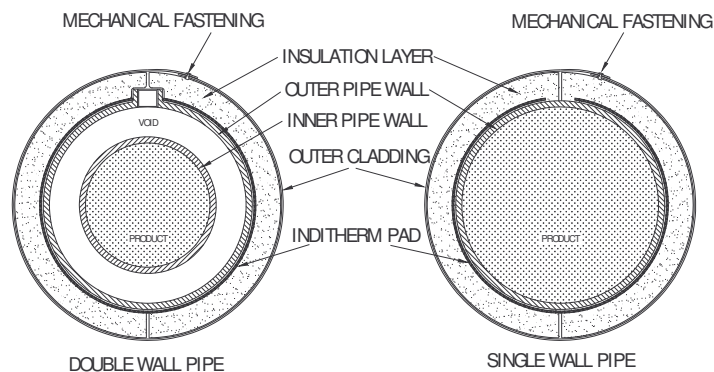

**Figure 5 - Inditherm Removable Jacket
over Single- and Dual-Walled Pipes**

Inditherm can also be applied to existing dual-walled pipes to replace hot water heating, without the need to replace the pipework. Provided the water connections are blanked-off and sealed, heat transfer is very effective.

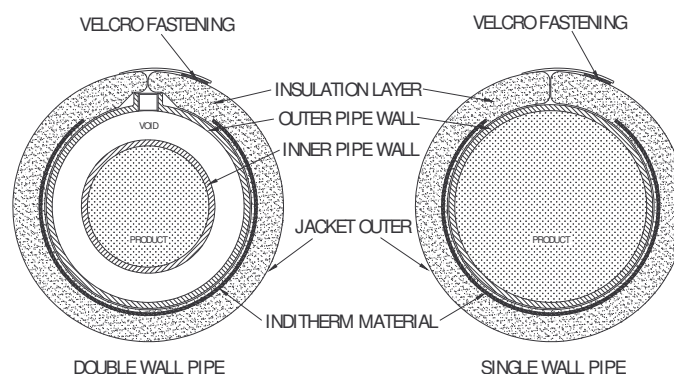

**Figure 6 - Inditherm Pad & Fixed Cladding
over Single- and Dual-Walled Pipes**

Cladding

Cladding is manufactured to ensure the highest possible levels of hygiene and electrical safety, as well as easy access to joints and flanges. Typical arrangements are shown below.

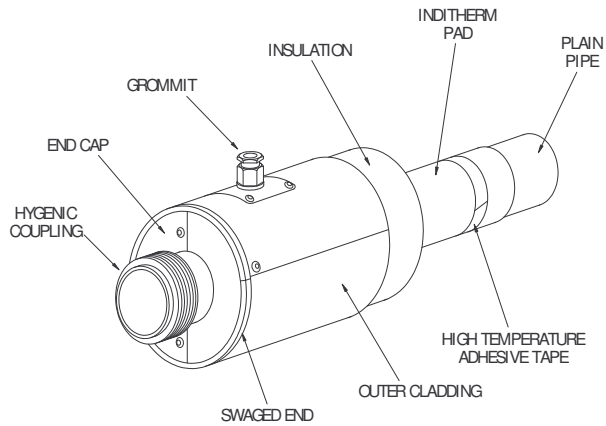

Figure 7 – Typical Cladding Arrangement around a Joint

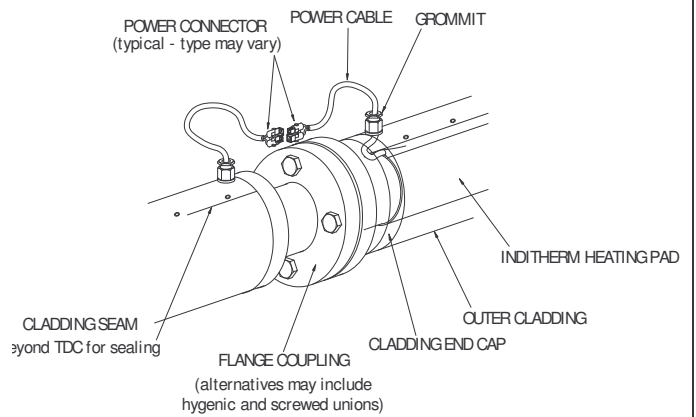

Figure 8 – Typical Cladding Arrangement around a Flange

Power Supply

The power supply and scheme should be laid out to minimise the effect of voltage drop. The control panel should therefore be located as near to the centre of the scheme as possible. A schematic of a typical layout is shown in Figure 9 below.

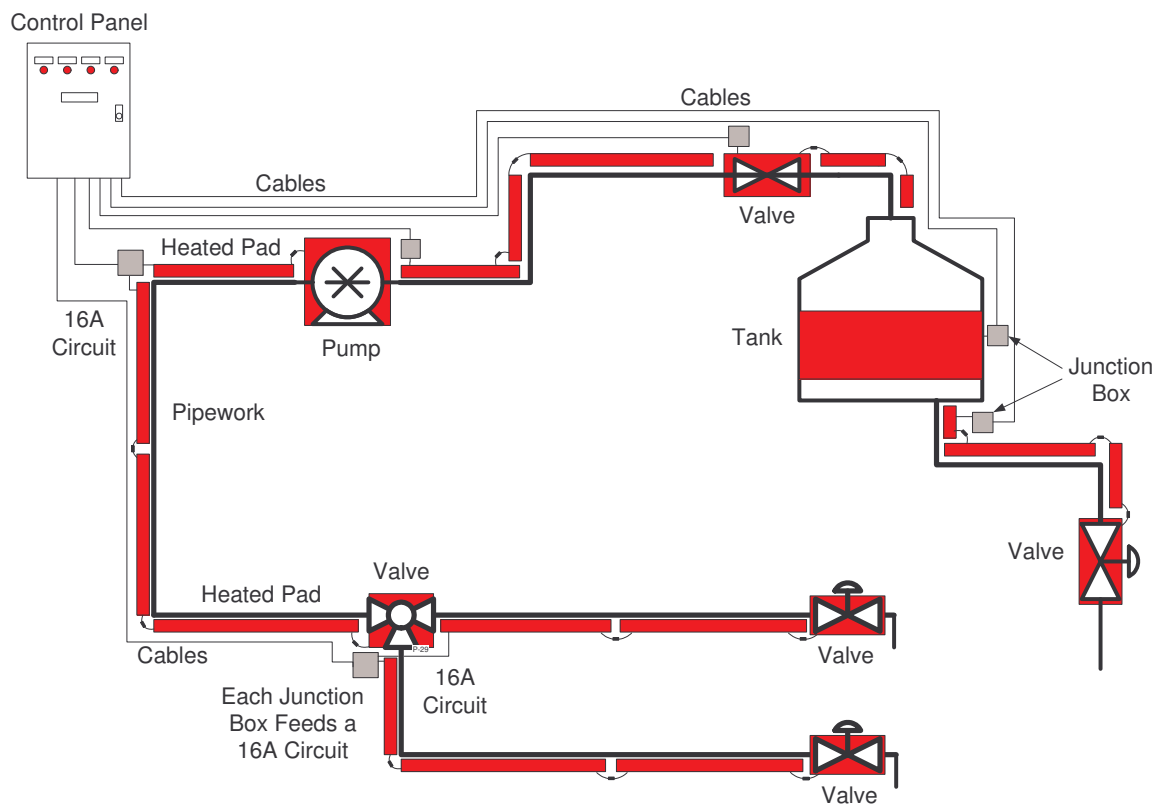

Figure 9 – Schematic of Power Supply and Wiring of Typical Industrial Process Heating System

Pipework

In some industries, such as food processing and pharmaceuticals, it is necessary to use extruded seamless pipe on the inner pipe of dual-walled systems heated by water. This is to prevent erosion of the weld and an eventual water leak, which at best results in product contamination and plant shutdown and at worst, serious damage to some of the process equipment. Such seamless pipework is expensive.

Because Inditherm is an electrical system, such corrosion concerns are eliminated, giving users the option to use lower cost, welded seam pipe with a machined interior.

Installation

Fitting removable jackets around pipework and associated equipment is straight-forward and can be completed quickly, minimising time on site. It is normally carried out by Inditherm technicians who can train plant operators how to remove and replace the jackets safely.

Heated jackets are wired together in parallel and terminated at intervals into junction boxes. Cables can be secured to the pipes or laid in cable trays adjacent to the pipework.

Unheated Systems

Inditherm's range of unheated removable jackets both significantly reduce energy costs and improve user safety. They are ideal for both insulation and noise reduction of pumps and other noisy machinery. Typical insulation applications include pipework, pumps, valves, IBCs, drums, cylinders, tanks and bulk storage vessels.

In many industrial installations it is common to leave valves, pumps, pipe work and flanges uncovered, resulting in high levels of heat loss and hot surfaces exposed, creating a potential H&S hazard.

Using insulated jackets that are custom designed to fit each installation, provides the correct level of insulation, so that heat losses are kept to a minimum. Designed to be removed for maintenance, each jacket can be individually taken off and refitted without affecting other parts of the installation. In addition, removable panels can be created to allow users access to sight glasses and other items close to the vessel.

Specifications

Temperature: From ambient up to 120°C.

Removable jacket cover material: High tenacity polyester with PVC coating on both sides. Weight to BS3424/5A: 560g/m² ± 25g/m². Cable entry through a waterproof grommet. Silicon coated glass cloth available for higher temperature applications and other materials to suit environmental conditions or factory standards available upon request.

Heating pads with fixed cladding: Inditherm CPT is encased in silicon coated glass cloth and taped to the pipe with glass tape. Insulation is normally 50mm, foil-faced mineral wool, over-clad by appropriate metal or plastic cladding to suit environmental and user needs (e.g., stainless steel, Aluzinc, Plastisol). Alternative insulation (e.g., polyurethane foam) is also available upon request. Cladding can be fastened by rivets, screws or banding, depending upon user requirements. All seams are mastic sealed and the ends capped.

Maintenance: The system has no moving parts, so maintenance is minimal. With removable jackets, users have the ability to examine pipework, etc., simply by undoing the draw cords and fasteners.

Cables: 2.5mm to 25mm PVC coated. Cables are sized to provide 16A with the minimal possible voltage drop. Cable entries are through appropriate grommets.

About Inditherm plc

Formed in 1998, marketing a new polymer based heating system, Inditherm is now established in numerous markets as a cost-effective provider of innovative solutions to difficult heating problems.

Applications include patient warming and muscle heat therapy within the medical sector, critical temperature management within industry, under pitch heating within sports stadia and as an accelerator for concrete curing in the construction market.

The Company is listed on the London Stock Exchange (AIM).

Inditherm Conductive Polymer Technology

Inditherm technology is based on a unique carbon-based polymer that generates uniform heat across its entire surface when energised by a low voltage power source.

The Inditherm conductive polymer technology (CPT) has fabric-like qualities and flexibility that enable it to be used on pipes and on most industrial components, including items with shapes that are normally difficult to heat. In addition, it is ideal for heating large, flat areas.

The Inditherm polymer will be encapsulated in an appropriate, insulated outer cover, depending upon the application. Heated pads can be made to a suitable length to fit between brackets, flanges, etc.

Contacts:

Inditherm Industrial
Houndhill Park
Bolton Road
Rotherham S63 7LG
South Yorkshire
United Kingdom

Tel: +44 (0) 1709 761000
Fax: +44 (0) 1709 761066

E-mail: sales@indithermplc.com

Website: www.inditherm.com